

presentatie
+ Drupal for e-learning

solide
websites & applications





1. Contents

1. Introduction
2. E-learning, Drupal
3. Existing contributions
4. Our projects
5. Goals and roadmap



2. Who is Eric Sol?

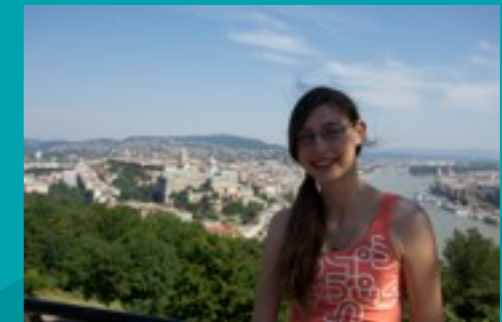



3. E-learning

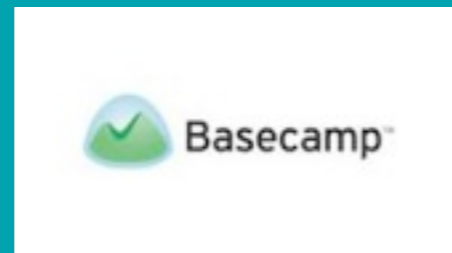



4. Some jargon...

(E)LMS or ELO: Learning Management System

LCMS: Learning Content Management System

LAMS: Learning Activity Management System

LRS: Learning Record Store

xAPI: Experience API

SCORM: Sharable Content Object Reference Model

ADL: Advanced Distributed Learning

IMS: Global Learning Consortium



5. E-learning building blocks

Content creation or import

Statistics

Content delivery

Workflow

Messaging

Class management

Assessment

Collaboration



6. Drupal

Drupal is a CMS	Drupal is a framework
WYSIWYG	Form and other API's
media integration	Hooks
mashups	Agile
editorial workflow	templating



7. Advantages using Drupal

- integrates well with website/blog
- general flexibility
- existing themes and theming
- granular permissions
- Hooks and API's
- many contributions
- many Drupal shops exist



8. Drupal for e-learning: basic usage





10. Drupal for e-learning: Course

- maintained by DLC Solutions
- 11K lines of code
- emphasis on learning paths
- integrates well with existing structures



11. Drupal for e-learning: Course II

Content creation or import

- integrates in admin/structure/types for course and course content
- tabledrag UI for learning paths
- access conditions based on progress, grades, calendar
- integrates with signup, certificate

Workflow

Collaboration

Assessment



12. Drupal for e-learning: Course II

Home » My First Course

My First Course

View Course outline Course reports Edit Enrollments Take course Outline Signups

Devel

Show row weights

-	Allquip Feugiat Quadrum <ul style="list-style-type: none">EnabledVisible in outlineCompletion requiredEdit instance	Article Course Content	Settings
+	Minim Voco <ul style="list-style-type: none">EnabledVisible in outlineCompletion requiredEdit instance	Article Course Content	Settings
-	Metuo Saeplus <ul style="list-style-type: none">EnabledVisible in outlineCompletion requiredEdit instance	Book Course Book	Settings
+	Poll <ul style="list-style-type: none">EnabledVisible in outlineCompletion requiredEdit instance	Poll Course Poll	Settings
-	Webform <ul style="list-style-type: none">The Webform has no questions. Please add questions.EnabledVisible in outlineCompletion requiredEdit instanceEdit questions	Webform Course Webform	Settings

- select object - Add object

Save outline

Statist

Me

livery

essment



13. Drupal for e-learning: Quiz

- maintained by KnackForge
- > 20K lines of code
- multiple choice questions with unlimited scales
- add markup (“directions”) to quiz
- integration for Google Chart API, views



14. Drupal for e-learning: Quiz II

Dashboard **Content** Structure Appearance People Modules Configuration Quiz Reports Help Hello admin Log out

Add content **Find content** Edit shortcuts

Home » Administration

Content CONTENT COMMENTS

[+ Add content](#)

SHOW ONLY ITEMS WHERE

status Filter

type

UPDATE OPTIONS

<input type="checkbox"/>	TITLE	TYPE	AUTHOR	STATUS	UPDATED	OPERATIONS
<input type="checkbox"/>	My First Quiz updated	Quiz	admin	published	10/22/2013 - 09:41	edit delete
<input type="checkbox"/>	Opgave 11U heeft een privérekening bij een bank... new	Multiple choice question	admin	published	10/22/2013 - 09:40	edit delete
<input type="checkbox"/>	I like this assessment new	Multiple choice question	admin	published	10/22/2013 - 09:34	edit delete



15. Drupal for e-learning: ELMS

Content creation or import

Statistics

Content delivery

- maintainer Bryan Ollendyke (btopro), PennState
- Drupal profiles with numerous modules
- >40K lines of code (hard to tell...)
- much emphasis on content creation and delivery
- “hub and spoke” architecture based on RESTful Web Services (restws)



16. Drupal for e-learning: ELMS II

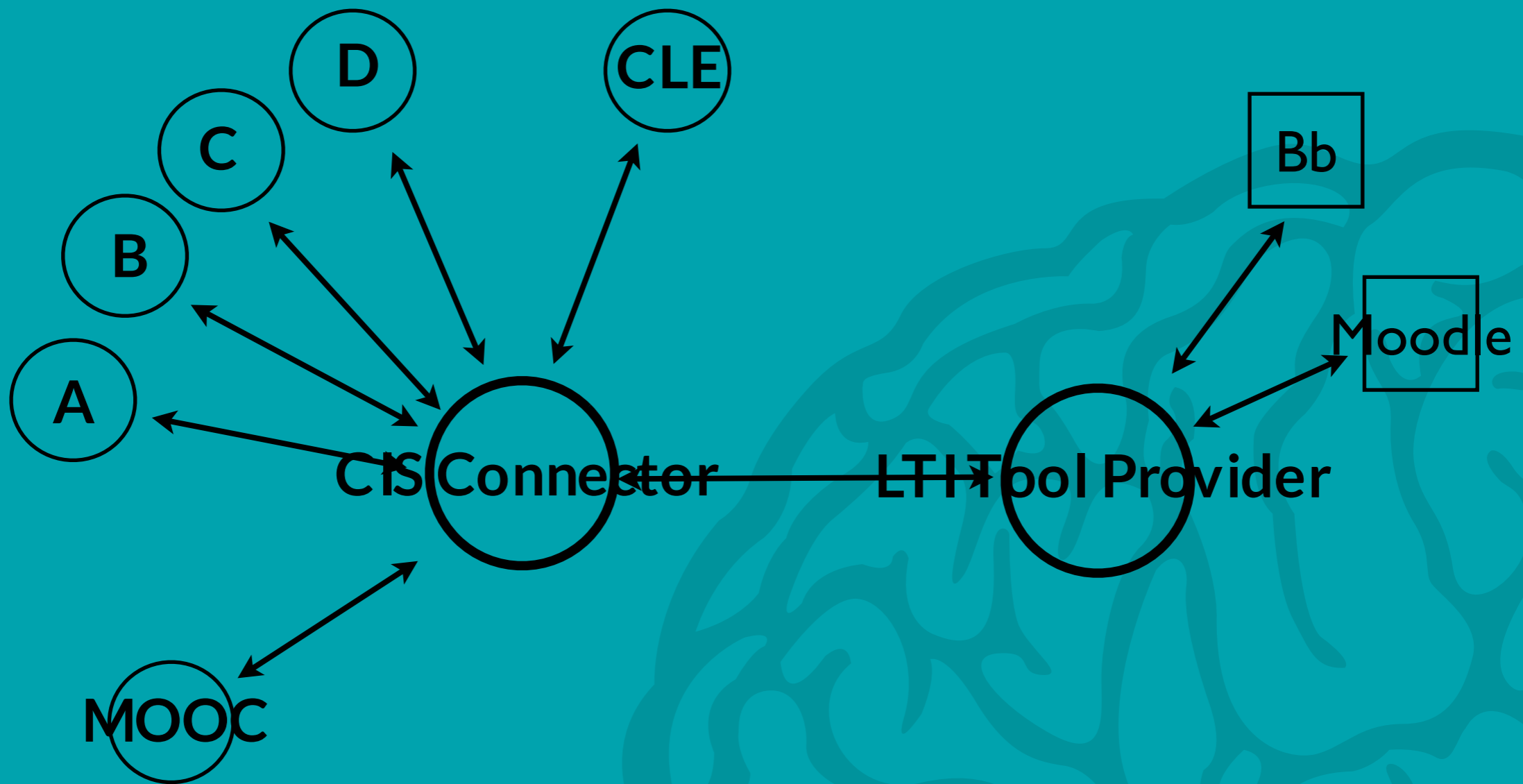



17. Drupal for e-learning: Open Atrium

- maintained by Phase2
 - Drupal profile
 - > 50K lines of code
 - intranet in-a-box
 - generic tool for collaboration
 - tied in with Panopoly
- Content creation or import
- Content delivery
- Statistics
- Workflow
- Class management
- Messaging
- Assessment
- Collaboration



18. Drupal for e-learning: Open Atrium II

The screenshot displays the Open Atrium II interface. At the top, there is a navigation bar with 'ADMIN', a home icon, 'default', and 'Space home'. A search bar and a user profile for 'admin' are also visible. Below the navigation bar, the main content area is titled 'default' and 'default space'. On the right side, there are two panels: 'Customize this page' and 'Change this layout'. Below these are buttons for 'Edit', 'Members', and a lock icon. A red 'Private' status panel indicates that only members can see the page. Below this, a message states 'You are the space manager'. A 'Section 1' link is also present. The main content area features a 'Recent Activity' section with a 'Filter' dropdown. The activity is dated 'TODAY, OCTOBER 22' and includes three entries: 'admin updated Document for Project A' at 1:00pm, 'admin created Section 1' at 12:59pm, and 'admin created Document for Project A' at 12:55pm. Each entry includes a plus sign and a truncated text snippet: '<p>Duis aliquet egestas purus in blandit. Curabitur vulputate, ligula...'. At the bottom of the page, there is a small green icon of a person with a checkmark.



19. Partner in Balans

- developed with ICT Wereld for Alzheimer Foundation/Maastricht University
- 9 modules, course-takers follow max. 4
- introduction -> explanation -> assignment -> plan
- emphasis on visual structure and (personal) feedback
- no custom code



20. Partner in Balans II



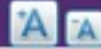

[Mijn account](#)
[Uitloggen](#)
[Berichten](#)

[Home](#)
[Uw modules](#)
[Forum](#)
[Over dit project](#)



Uw Modules

Focussen op het positieve

- Inventariseren wat samen wel nog mogelijk is
- Niet alles preventief opgeven
- Mogelijke alternatieven zoeken of veranderingen aanvaarden

1	Introductie filmpje
2	Toelichting
3	opdracht-deelnemer2-Focussen op het positieve
4	stappenplan-deelnemer2-Focussen op het positieve

De veranderende partner

- Inzicht in geheugenklachten
- Inzicht in gedragsveranderingen
- Leren hoe geheugenklachten invloed hebben op het functioneren van u en uw partner

Uw Coach



coach2
T: 043 - 388 1995
[Klik voor hulp](#)
[Maak bericht](#)



21. Partner in Balans III

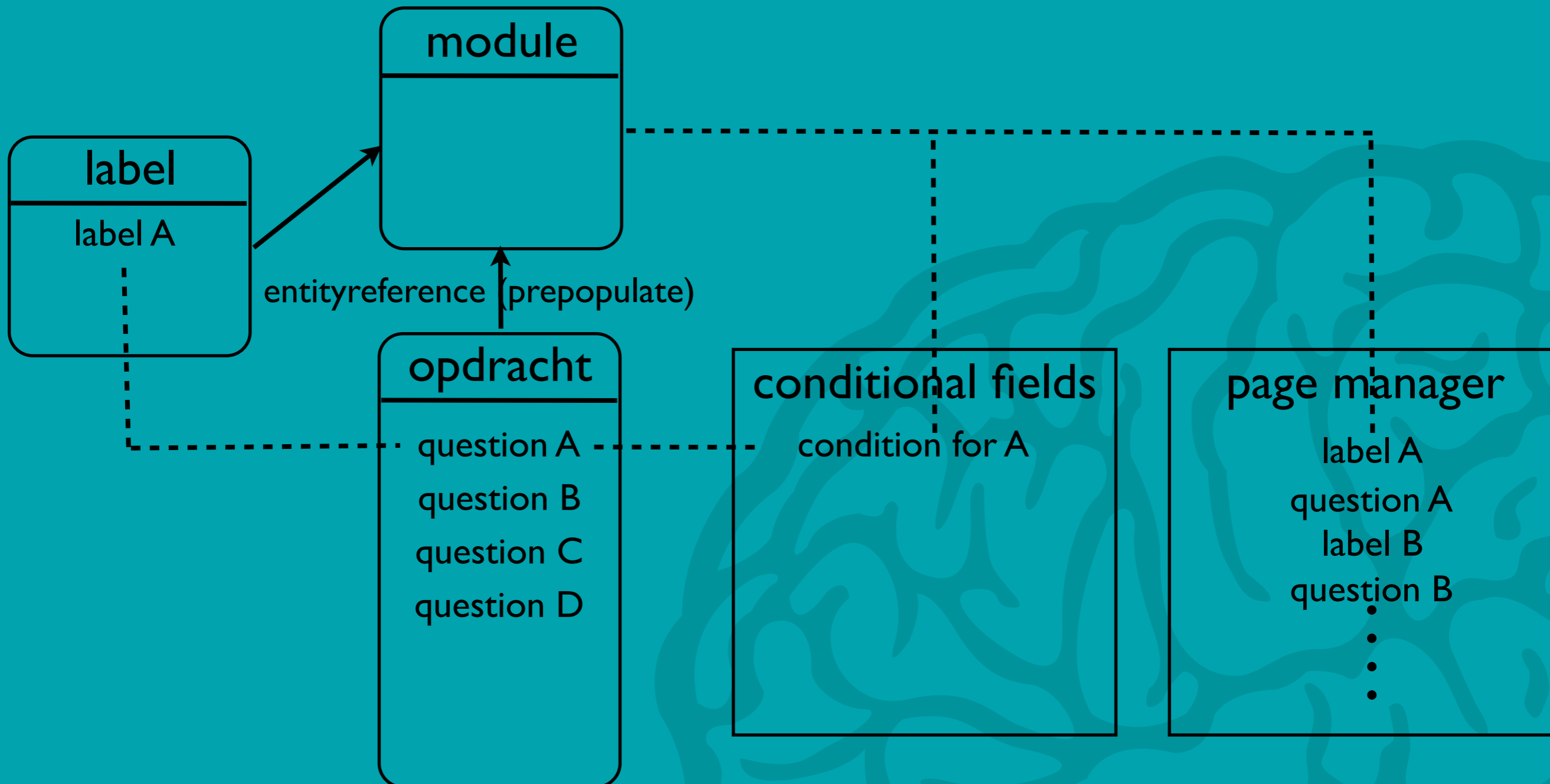



22. Klikopwerk

- self-assessments and matching for beneficiaries
- requirements mostly set by Goeree-Overflakkee
- emphasis on usability, styling and performance
- ~2K custom code (mainly `hook_form_alter`)



23. Klikopwerk II

klikopwerk iedereen doet mee
Welkom, Tjolk
Uitloggen

1 nieuw bericht home caseload profielenmatch kandidatenmatch accounts profielen bedrijven

Koos Koets
BSN: 987623123
Geboortedatum: 04-05-1958
Geslacht: man
Beschikbaar vanaf: 19-06-2013
Vervoermiddelen: Brommer of scooter

NAW gegevens
Naam: Koos Koets
E-mailadres: koos@solidegroep.nl
Adres: Koetswerk 14
3221AK Julinen
Nederland

Persoonlijke kwaliteiten

Kwaliteit	Waarde	Verandering
Emotionele stabiliteit	90%	▲ 2%
Extraversie	80%	▲ 1%
Resultaatgerichtheid	67%	▼ 2%
Samenwerkingsvermogen	60%	▲ 6%
Vernieuwingsgerichtheid	50%	▼ 7%

Werk kwaliteiten

Kwaliteit	Waarde	Verandering
Aanpassen en aankunnen	100%	▼ 10%
Analyseren en interpreteren	25%	▼ 4%
Creëren en leren	0%	▼ 1%
Leiden en beslissen	0%	▼ 7%
Netwerken en overtuigen	67%	▲ 2%
Ondernemen en presteren	33%	▼ 4%
Ondersteunen en samenwerken	50%	▼ 6%
Organiseren en uitvoeren	50%	▼ 14%

Rekenen

Rekenen	Waarde	Verandering
Rekenen 1F		▼ 62%
Rekenen 2F		▼ 39%

Meer details
volledig rapport
toon CV
toon certificaat
account en NAW
profiel
opleiding & werk
ervaring & belangstelling

Casemanager
Tjolk Hekking
tjolk@solidegroep.nl
0123 456789

Verstuur bericht →
Leeswijzer

5.6
6.5

Gemaakt door **Hollands** **eed**

<https://demo.klikopwerk.nl/node/4821?width=500&height=500>



24. Klikopwerk III

- integrate with content types (like Course)
- Field Collection for rubrics, maybe switch to Multifield
- question content type for flexibility in questions

Main issues:

- cardinality based on field, not instance
- save as draft or autosave nodes



25. Roadmap for these projects

- contribute assessment module (> 17/11)
- klikopwerk v 1.1 early 2014
- klikopwerk v2.0 summer 2014
- e-learning in klikopwerk end 2014

- partnerinbalans v2.0 unsure (pilot running)



26. Building blocks for (our) e-learning

- course module is good starting point
- evaluate different data structures (field collection, content template, multifield, delta's)
- integration of assessment with course
- use OG for “classes”, cherry pick from Open Atrium
- single database or ELMS/RESTful architecture
- ignore D8 for now



Stay tuned:
eric@solide-ict.nl